

## 迴轉沖削刀座 /Rotary Broaching Tool Holders

### ■ TYPE:BCM21

最大推力 400daN  
Max. Thrust 400daN

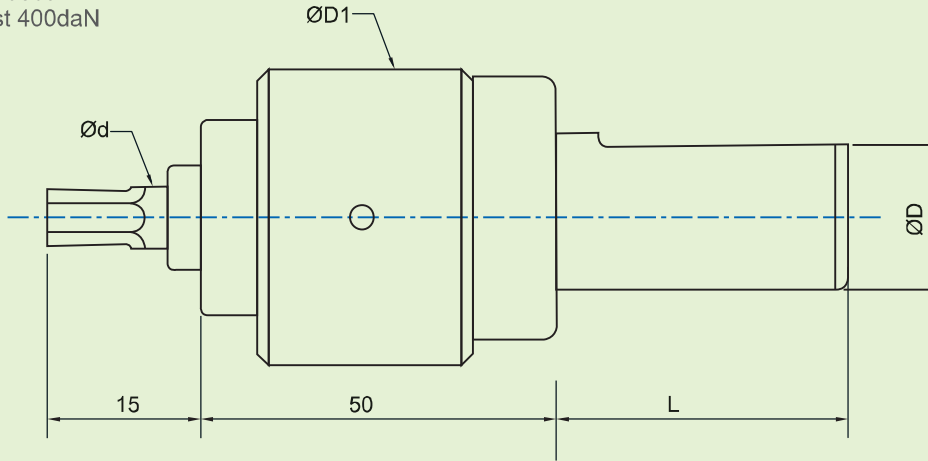

產品規格 Model No.	尺寸 Dimensions				沖刀 Insert	應用範圍 Scope of application
	D	D1	d	L		
BCM21-ST16	16	38	8	38	BCM32-***	六角形 (Hexagonal) 星形 (Torx) 正方形 (Square) 溝槽 (Grooves) 特殊外形 (Special Profiles)
BCM21-ST20	20					

### ■ TYPE:BCM22

最大推力 1000daN  
Max. Thrust 1000daN

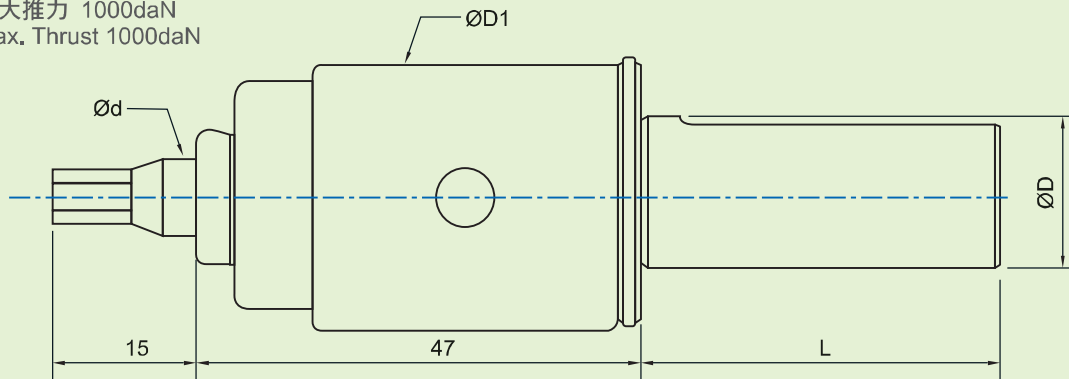

產品規格 Model No.	尺寸 Dimensions				沖刀 Insert	應用範圍 Scope of application
	D	D1	d	L		
BCM22-ST16	16	28	8	38	BCM32-***	六角形 (Hexagonal) 星形 (Torx) 正方形 (Square) 溝槽 (Grooves) 特殊外形 (Special Profiles)
BCM22-ST20	20			38		
BCM22-ST20-60	20			60		
BCM22-ST25	25			60		