

## 附螺母型鎢鋼固定頂針

## TYPE:355

## SOLID CENTERS OF CARBIDE TIPPED WITH DRAW-OFF NUT

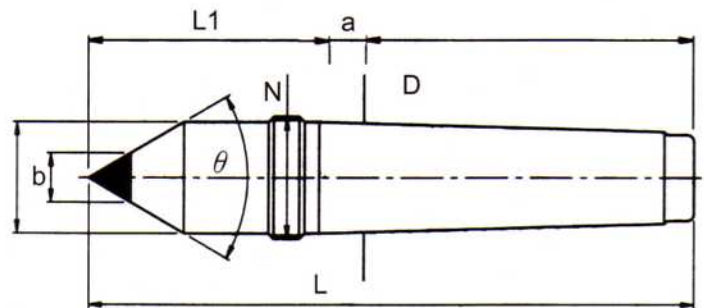

### 特性:

- (1)本體使用"S45C"之材質：經過熱處理。
- (2)本體及頂心經過精密研磨處理。
- (3)適用於車床及磨床等機械。
- (4)外徑斜度(Morse Taper)採用DIN806規格。

### Characteristics:

- (1)Body is made of "S45C" with heat treatment.
- (2)Body and Center is under precise grinding process.
- (3)Application to lathe and grinder.
- (4)Morse Taper complies with DIN806 standard.

單位:m/m

產品編號 STYLE No.	產品規格 MODEL No.	D	a	b	L1	L	N	Co.精度 Accuracy	$\theta = \theta 1$
355-02006-1600	MT2C06E16-N	17.780	5	6	47	116	M22x1.5	0.005	60°
355-03010-2700	MT3C10E27-N	23.825	5	10	66	152	M27x1.5	0.005	60°
355-03014-3000	MT3C14E30-N	23.825	5	14	67	155	M27x1.5	0.005	60°
355-04014-4100	MT4C14E41-N	31.267	6.5	14	87	196	M36x1.5	0.005	60°
355-04018-0700	MT4C18E07-N	31.267	6.5	18	53	162	M36x1.5	0.005	60°
355-04025-4100	MT4C25E41-N	31.267	6.5	25	97	206	M36x1.5	0.005	60°
355-04030-1500	MT4C30Full-170N	31.267	6.5	31.6	61	170	M36x1.5	0.005	60°