

精密型互換式迴轉頂針

TYPE:530

EXCHANGEABLE LIVE CENTERS FOR PRECISION

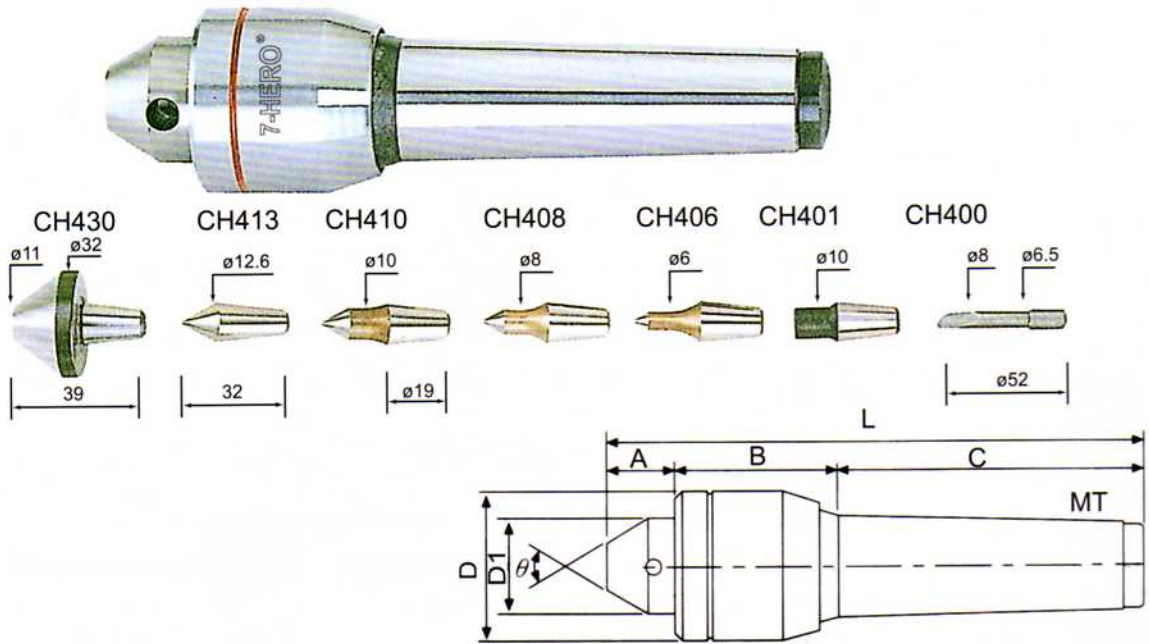

特性:

- (1)心軸及本體使用"合金鋼"之材質,經適當熱處理為(HRC60°±2°),具有高剛性。
- (2)此頂針使用止推軸承,滾針軸承及滾珠軸承之組合。使用航太潤滑油脂,具防水性。
- (3)適用於中負荷或中、高速車床等之加工切削。
- (4)可更換不同尺寸之頂心,便於加工工件。

Characteristics:

- (1)Center and shaft is made of "Bearing Steel" under appropriate heat treatment (HRC60°±2°) with high rigidity.
- (2)Center is assembled with thrust bearing, needle ball bearing, and roller bearing, and adopts lubricant grease with waterproof quality.
- (3)Applicable to medium duty load, or high-speed lathe, etc. processing or cutting.
- (4)Center is exchangeable with different size, and is available for workpiece processing.

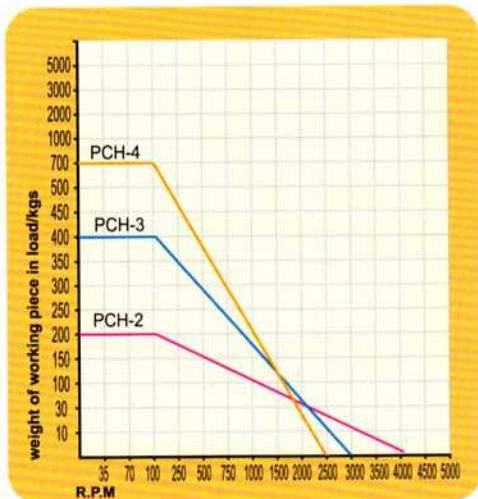

單位:m/m

產品編號 STYLE No.	產品規格 MODEL No.	A	B	C	D	D1	L	Co.精度 Accuracy	Max. R.P.M	Max. Wt	θ
530-02000-0000	PCH2 (MT2)	22	36	69	32	25	127	0.005	4000	200	60°
530-03000-0000	PCH3 (MT3)	23	44	86	41	30	153	0.005	3000	400	60°
530-04000-0000	PCH4 (MT4)	23	51	108	47	32	182	0.005	2500	700	60°