

## 標準型鑽床夾頭

## TYPE:101

### KEY-TYPE DRILL CHUCKS OF STANDARD

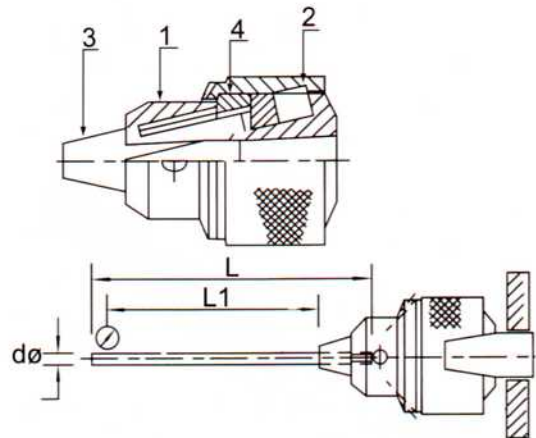

#### 特性:

- (1) 為標準產品,超精密及耐磨持久。
- (2) 所有零件都經過內、外精密研磨處理。
- (3) 應用於中負荷使用之。
- (4) 零件分析表:(A)
- (5) 偏轉量和轉矩檢驗表:(B)

#### Characteristics:

- (1) Standard product with super precision and long durability.
- (2) All parts are treated under interior and exterior grinding process.
- (3) Applicable to medium heavy load.
- (4) Material Analysis Table:(A)
- (5) Run-out Accuracy & Torque Inspection Table:(B)

#### ■零件分析表:(A)

零件號碼 Part No.	零件名稱 Part Name	材質 Material	硬度 Heat-Treatment
1	本體 Body	SCM21	HRC55°~58°
2	鑲塊 Case	SCM21	HRC55°~58°
3	三爪 Jaws	SUJ2	HRC61°±2°
4	螺桿 Nut	SUJ2	HRC61°±2°

#### ■偏轉量和轉矩檢驗表:(B)

單位:m/m

產品型號 MODEL No.	1/4"	3/8"	1/2"	5/8"	3/4"	1"
圓棒直徑 Ød	6	9	12	15	18	24
圓棒長度 L1	70	85	110	120	120	140
圓棒長度 L	90	110	140	150	150	180
最大偏轉量 Max Run-out	0.08	0.08	0.08	0.08	0.08	0.08
轉矩(kgf-cm) Torque	50	100	210	260	300	400

單位:m/m

產品編號 STYLE No.	產品規格 MODEL No.	內孔斜度 DIN or JACOBS	夾持範圍 Clamping Capacity (mm / inch)	直徑 D	長度		淨重 Wt (kgs)	板手 型式
					開 B	閉 A		
101-02010-0605	1/4"	J1	0.5-6.5 / 1/64"-1/4"	40	40	50	0.20	T
101-02100-0605	1/4"	B10	0.5-6.5 / 1/64"-1/4"	40	40	50	0.20	T
101-03020-1005	3/8"	J2	0.5-10.0 / 1/64"-3/8"	50.5	50.5	64	0.39	T
101-03120-1005	3/8"	B12	0.5-10.0 / 1/64"-3/8"	50.5	50.5	64	0.39	T
101-04060-1305	1/2"	J6	0.5-13.0 / 1/64"-1/2"	53	69	82	0.85	T;P
101-04330-1305	1/2"	J33	0.5-13.0 / 1/64"-1/2"	53	69	82	0.85	T;P
101-04160-1305	1/2"	B16	0.5-13.0 / 1/64"-1/2"	53	69	82	0.85	T;P
101-05030-1610	5/8"	J3	1.0-16.0 / 1/32"-5/8"	56	78	96	1.00	P
101-05180-1610	5/8"	B18	1.0-16.0 / 1/32"-5/8"	56	78	96	1.00	P
101-06040-1930	3/4"	J4	3.0-19.0 / 1/8"-3/4"	89	89	126	2.15	P
101-06220-1930	3/4"	B22	3.0-19.0 / 1/8"-3/4"	89	89	126	2.15	P